

2/2

HOT WATER AND STEAM VALVES

MAGNALIFT

BRASS

PIPE MOUNTING

NORMALLY CLOSED

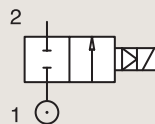

Port size	Orifice Ø	Flow factors			Operating Pressure Differential			Fluid Temp.		Seat Seal	Valve Ref.	Housing Ref.	Coil Ref.	Power		Coil Group	Dwg. No.
		Kv l/min	KV m³/h	Qn l/min	Min bar	Max(MOPD) AC bar	DC bar	Min °C	Max °C					AC W	DC W		
3/8"	15	65	3.9	-	0	10	-	0	100	EPDM	221G1303	2995	481865	8	-	2.0	3732
	15	65	3.9	-	0	10	-	0	120	EPDM	221G1303	4270	481000	8	-	2.0	3732
	15	65	3.9	-	0	4	4	0	140	EPDM	221G1303	4270	486265	14	14	2.0	3732
	15	65	3.9	4500	0	10	10	-10	100	NBR	221G1330 ₁	2995	481865	8	9	2.1	3732
	15	65	3.9	4500	0	10	10	-10	65	NBR	221G1330 ₁	-	492070	9	8	2.1	3732
1/2"	15	65	3.9	-	0	10	-	0	100	EPDM	221G1503	2995	481865	8	-	2.0	3732
	15	65	3.9	-	0	10	-	0	120	EPDM	221G1503	4270	481000	8	-	2.0	3732
	15	65	3.9	-	0	10	7	0	140	EPDM	221G1503	4270	486265	14	14	2.0	3732
3/4"	15	80	4.8	-	0	10	-	0	100	EPDM	221G1603	2995	481865	8	-	2.0	3444
	15	80	4.8	-	0	10	-	0	120	EPDM	221G1603	4270	481000	8	-	2.0	3444
	15	80	4.8	-	0	4	4	0	140	EPDM	221G1603	4270	486265	14	14	2.0	3444
1"	15	80	4.8	6000	0	10	-	0	100	EPDM	221G1703	2995	481865	8	-	2.0	3445
	15	80	4.8	6000	0	10	-	0	120	EPDM	221G1703	2995	481000	8	-	2.0	3445
	15	80	4.8	6000	0	10	10	0	140	EPDM	221G1703	2995	486265	14	14	2.0	3445

Notes:

1. Valves with model number ending in 30 or 31 are mainly equipped with electrical parts for explosion proof applications or with standard DC coils.



For this page	Port size	Orifice (mm)	Kv (l/min)	MOPD (bar)	Fluid Temp (°C)
From	3/8"	15	65	4	-10
To	1"	15	80	10	140

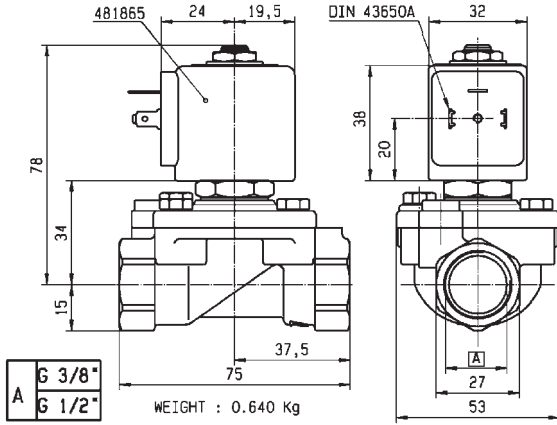

Drawing 3732

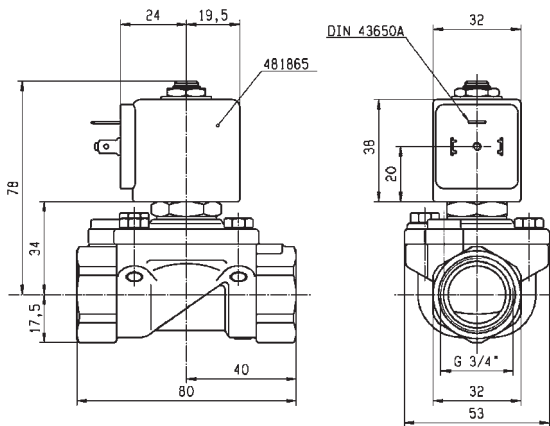

Drawing 3444

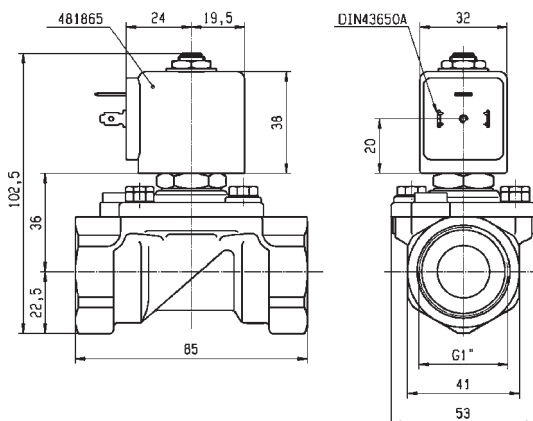

Drawing 3445